

# Processor Research Team

## 1. Team Members

Makoto Taiji (Team Leader)  
Yousuke Ohno (Senior Research Scientist)  
Noriaki Okimoto (Senior Research Scientist)  
Gentaro Morimoto (Research Scientist)  
Takao Otsuka (Research Scientist)  
Yoshinori Hirano (Research Scientist)  
Tomoki Kobori (Postdoctoral Researcher)  
Yohei Koyama (Postdoctoral Researcher)  
Aki Hasegawa (Research Associate)  
Yumie Ohyama (Assistant)

## 2. Research Activities

The aim of the processor research team is to create a future basis of high-performance processors for scientific simulations, as well as to explore the processor performance of the K computer.

In future high performance computing, we have to tackle with millions or more parallel operation units to extend the performance. However, many applications require acceleration while keeping the problem size, i. e. the strong scaling, and they can often be parallelized up to thousands of core, not to millions. To achieve better strong scaling, we have to decrease the cost of parallelization by improving the latency in everywhere – network, main memory, and processors. For this, we will try to develop the platform of System-on-Chip (SoC) based accelerators. It consists of general-purpose processor cores, memories, network units and computing accelerators on the single chip. By such integration we aim to achieve the ultimate performance for selected applications.

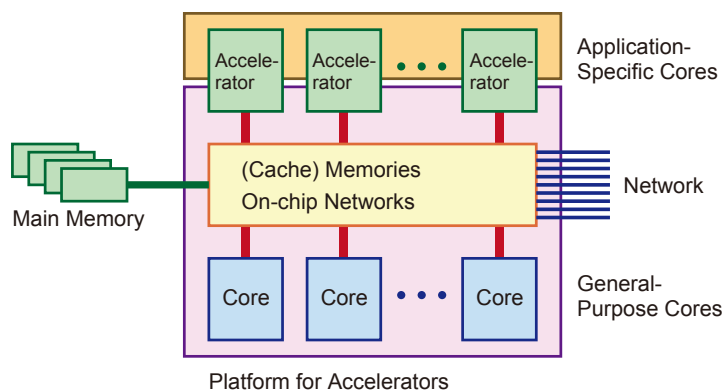

Fig. 1. Diagram of platform for accelerators.

In addition to the researches on future computing platform, we will contribute to accelerate the application performance on the K computer. The processor of K computer, SPARC64 VIIIfx, has several special features for high-performance computing called VISIMPACT and HPC-ACE. We will explore to extract its power for several applications based on our experience on the processor architecture.

### 3. Research Results and Achievements

#### 3.1. Platform of accelerators

In this year we evaluated the MDGRAPE-4 SoC in RIKEN QBiC (Quantitative Biology Center) using the test board of the MDGRAPE-4 system. We have confirmed the basic operation of SoC. We are porting GROMACS software for the MDGRAPE-4 system with Prof. Lindahl, Stockholm University.

From the viewpoint of the platform of SoC based accelerator, we can use as the MDGRAPE-4 SoC as the basis. It has 65 general-purpose (GP) processor cores, 64 dedicated pipelines for molecular dynamics force calculation, main memories, and network units for 3-dimensional torus network. By replacing the dedicated pipelines we can use the design as the platform of accelerators. The operation frequencies of the dedicated pipelines and the GP cores are 0.8 GHz and 0.6 GHz, respectively. For the inter-process synchronization, the queue system in the GP core is used. The pipeline units, the GP cores, and the network units exchange message with the control GP core, which takes control of a whole calculation. The SoC also contains a shared memory unit of 1.8MB. The size of SoC is  $15.6 \times 15.6 \text{ mm}^2$ , and is fabricated by the Hitachi HDL4S 40nm bulk CMOS technology. Its pipelines can evaluate 51.2G interactions/sec, which is equivalent to 2.56 Tflops performance when we count the calculation cost of a nonbond force and a potential as 50 flop.

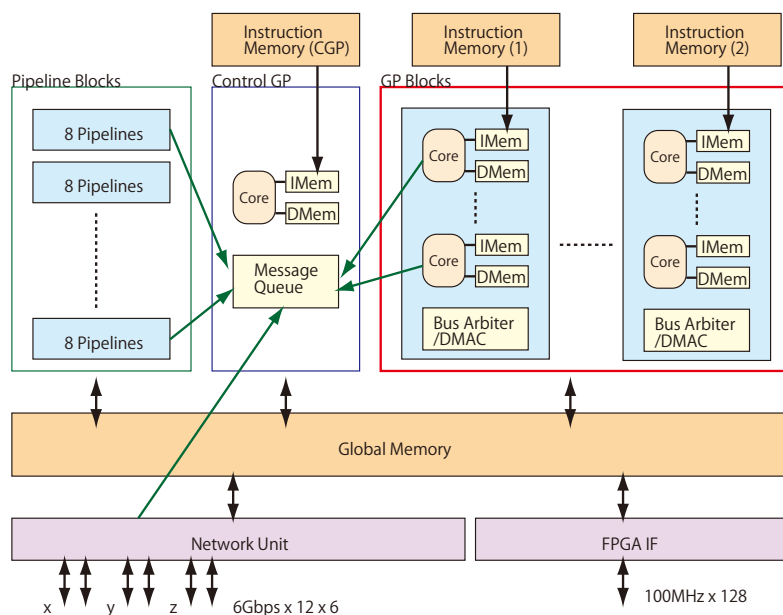

Fig. 2. Block diagram of MDGRAPE-4 SoC.

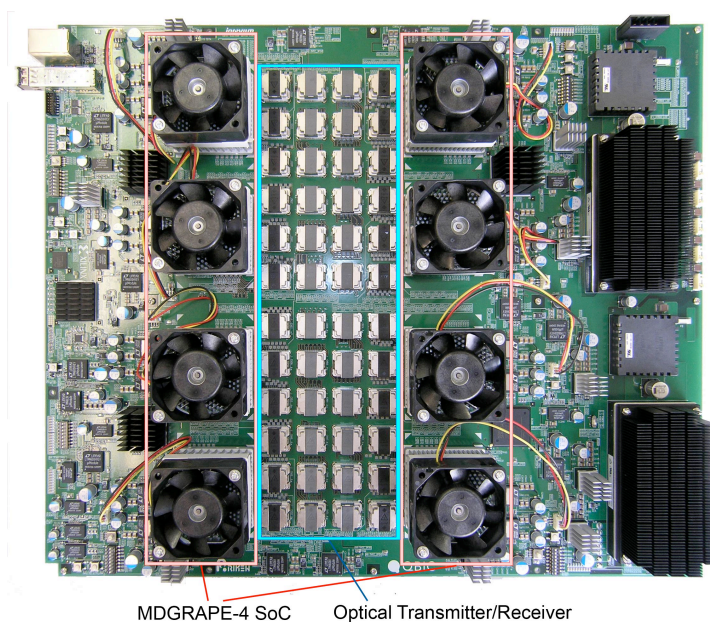

Fig. 3. MDGRAPE-4 system board.

### 3.2 Application Optimization on K computer

For application optimization we have optimized the molecular dynamics core code.

## 4. Schedule and Future Plan

In the next year, we will finish the MDGRAPE-4 System in RIKEN QBiC. In future, we will continue to implement the part of the MDGRAPE-4 SoC as the platform of accelerators. We will also

develop network-on-chip architecture for specific purposes like machine learning/ neural network. We will continue the optimization of MD core and the other codes for the K computer. We will also start the drug design and medical application of high-performance computing with Prof. Yasushi Okuno, senior visiting scientist.

## 5. Publication, Presentation and Deliverables

### (1) Invited Talks

- [1] Makoto Taiji, “MDGRAPE-4: a special-purpose computer system for molecular dynamics simulations,” Royal Society Kavli Seminar on “Multiscale systems: linking quantum chemistry, molecular dynamics, and microfluidic hydrodynamics”, Chicheley Hall, Buckinghamshire, UK (2013/7/22-23).
- [2] Makoto Taiji, “MDGRAPE-4: a special-purpose computer system for molecular dynamics simulations,” Plenary Lecture, Joint Workshop on Bio-inspired Engineering and Bio-supercomputing, Chiba University, Chiba, Japan (2014/3/3-4).